

NIB600 Microscope Specification					
		NIB610	NIB610--FL	NIB620	NIB620-FL
Optical System		NIS Infinite Optical System (F200)			
Observation method		Brightfield, Phase Contrast, Hoffman phase Contrast, Emboss Contrast	Brightfield, Phase Contrast, Hoffman, phase Contrast, Emboss Contrast, Epi Fluorescence	Brightfield, Phase Contrast, Hoffman phase Contrast, Emboss Contrast	Brightfield, Phase Contrast, Hoffman, phase Contrast, Emboss Contrast, Epi-Fluorescence
Illumination	Transmitted illumination	3W S-LED		3W S-LED Kohler Illumination	
	Episcopic illumination		LED illuminator, built-in Fly-eye lens, Can be configured with up to 3 different fluorescence LED units; available wavelengths:365, 405, 485, 525nm		LED illuminator, built-in Fly-eye lens, Can be configured with up to 3 different fluorescence LED units; available wavelengths:365, 405, 485, 525nm
Viewing Head		Seidentopf Viewing Head, Inclined at 45°, Interpupillary 48-75mm; Additional camera port eyepiece /port 100/0 : 0/100			
Eyepiece(F.O.V)		SW10×(22), WF15×(16), WF20×(12)			
Focusing		Coaxial coarse and fine adjustment, the function of coarse tightness adjustment, Fine Division 1 um, Fine stroke 0.2mm per rotation, Coarse stroke 37.5mm per rotation. Up 7mm, down 1.5mm.			
Nosepiece	Quintuple Nose-piece	x	x		
	Coded Quintuple Nosepiece			x	x
LCD Screen		Function display magnification, timing sleep, brightness indication and lock, etc.			
Condenser		Condenser NA 0.3, WD 75mm, without Condenser WD 187mm			
Stage		Stage: 170 (X) × 250 (Y)mm Attachable Mechanical Stage: 128 (X) × 80 (Y), Accepts 5 types of micro-testplate, well clammer and stage clip.			
Phase System		Condenser with 4x Phase Annulus Plate 10x, 20, 40x Universal Phase Annulus Plate			
Hoffman Phase		10×、20×、40× Hoffman Condenser, Special objective			
Relief 3D Contrast		Condenser and Eyepiece with Emboss Contrast 10×、20×、40×, Universal Emboss contrast slide			
Epi-Fluorescence Attachment			Filter cubes with noise terminator mechanism Configure with up to 3 Epi-fluorescence filter cubes, Attachable Contrast Shield.		Filter cubes with noise terminator mechanism Configure with up to 3 Epi-fluorescence filter cubes, Attachable Contrast Shield.
Dimensions		244 (W)×543 (D)×526 (H)mm	244 (W)×559 (D)× 526 (H) mm	244 (W)×543 (D)× 526 (H)mm	244 (W)×559 (D)× 526 (H) mm
Video Adapter		1×、0.5×, C Mount			
Accessories		ECO (No operator, turn off the light source automatically in 15 minutes) ; Heating Stage			

**Nexcope**<sup>®</sup>  
Scientific research microscope

NINGBO YONGXIN OPTICS CO.,LTD.

No.385Mingzhu Road, Hi-tech Industry Park, Ningbo, China

Tel: +86-0574-87915339

Fax: +86-0574-87903144

E-mail: lf@yxopt.com

http://www.nexcope.com

# CULTURE MICROSCOPE



INVERTED BIOLOGICAL MICROSCOPE FOR CULTURE

# NIB600

Professional Cell Observation, Explore Genetic Mysteries

**Nexcope**<sup>®</sup>  
Scientific research microscope



INTELLIGENT  
COMFORTABLE  
ACCURATE

# NEXCOPE NIB600

1. Make Reasonable improvement on basis of scientific research microscope. More suitable for laboratory observation of cells.
2. Adopt long life LED light source and infinity optical system, easy to obtain high-definition and high contrast wide viewing images.
3. The body is compact and stable, and the operation buttons are well arranged, the cells can be observed, sampled and processed in the super clean bench freely.
4. Using 3 different color filter, it widely enlarges selectivity for dye. LED illumination with large intensity and even brightness provides support for high quality fluorescence observation.
5. With standard camera port, Nexcope camera and image processing software, providing low noise, high sensitivity and resolution imageity and resolution image

## Professional Cell Observation

### Ergonomic design, comfortable operation

#### · 45° Inclined Viewing Head

Inclined viewing head makes the user to operate microscope in a comfortable position. Minimize muscle tension and discomfort caused by long working hours.

#### · Long-handle mechanical stage

The user can make comfortable and smooth movement during the operation, thereby improving work efficiency and comfort.



### High brightness, long lifetime LED Illumination

#### · LED illuminator, suitable for various observation

With a high brightness and long lifetime LED illumination system for both transmission and fluorescent lighting, proving even brightness and cool lighting.

	NIB610/NIB620	NIB610-FL/NIB620-FL
Transmitted	Bright Field ,Phase Contrast ,Hoffman Phase,Emboss Contrast	
Fluorescent	-	Epi-Fluorescence

### Intelligent operating system

#### Objective coding converter

It can memorize the illumination brightness when using each objective. When different objectives are converted to each other, the light intensity is automatically adjusted to reduce visual fatigue and improve work efficiency.

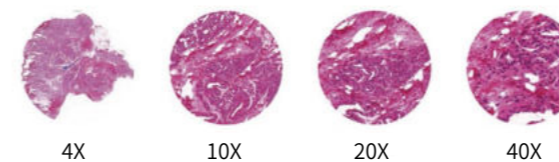

#### Use a dimming knob to achieve multiple functions

Click: Enter standby status

Double click: light lock or unlock

Rotation: Adjust brightness

Press + up-spin: Switch to the upper light source

Press + down-spin: Switch to the under light source

Press 3 seconds: Set the time of turning off the light after leaving

#### The display of microscope use state

The liquid crystal screen on the front of the microscope can display the using state of the microscope, including magnification, light intensity, standby status, and so on.



Start & working mode    Lock mode    Turn off the light after leaving mode    standby mode



## More convenient for cell sampling and aseptic manipulation

The microscope control mechanism is reasonable in layout and easy to operate

The frequently used control mechanisms are close to the user and in low-hand position. This kind of design makes operation more quickly and conveniently, and reduce the fatigue caused by the long observation. On the other hand, it reduces the airflow and dust caused by large amplitude operation, and it is very effective to reduce the probability of sample pollution. It is a strong guarantee for the accuracy and repeatability of the experimental results.



The body is compact, stable and suitable for clean bench



- Can be sterilized in the clean bench

On the premise of ensuring the effect of imaging, NIB600 is with relative compact design. The volume and weight of the body is reduced as much as possible in principle of stability. The compact body is with anti-UV coating and can be placed into the clean bench for sterilization under UV lamp.

- Cell sampling and operation can be performed in clean bench

The distance between the eye point to the operation button and the focusing knob of the NIB400 is relatively short, and the distance from the stage is far away. It is available to make the viewing head and operating mechanism outside, and stage, objectives and sample inside. So realize cell sampling and operation inside and observing comfortably outside.



Various holders for different culture containers

Various holders are available for different culture containers, such as Petri dishes, well plates, and culture flasks. As well as available for different size Petri dishes.



Detachable condenser

When culture flask is used, the condenser can be removed to increase working distance. It is also suitable for multilayer culture flask.



## Transmission

Phase Contrast

By using changes in the refractive index, high contrast microscopic images of transparent samples can be obtained with phase contrast observation technique. The advantage is that the details of live cell imaging can be obtained without staining and fluorescent dyes. Application range: Living cells in culture, Microorganism, Tissue slide, Subcellular grains (including cell nuclei and organelles).

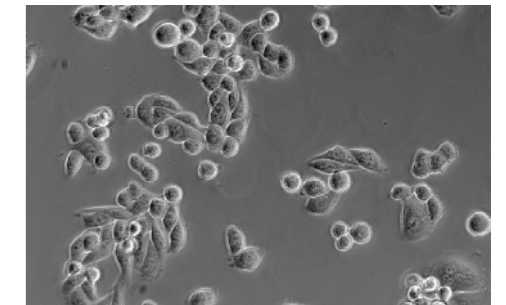
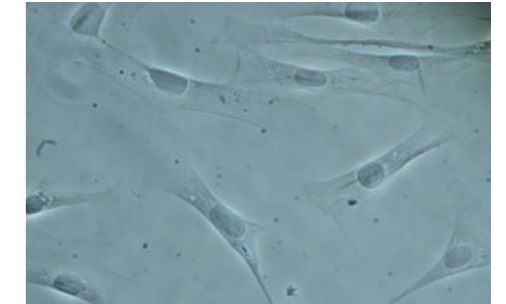

Hoffman Modulation Phase Contrast

With slant light, changing phase gradient into light intensity variety, it can be used to observe unstained cells and living cells.

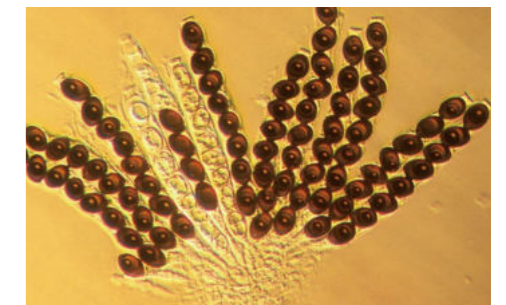

3D Emboss Contrast

Even without extra optical components, no glare 3D image can be obtained just through adding adjustment slider. Both glass and plastic Petri dishes are available.



# Fluorescent observation

LED light makes fluorescent observation easier

• **Uniform brightness**

Matching with Kohler illumination, the Fly-eye lens delivers uniform brightness to the entire field of view, whether through the eyepiece or through CCD camera.

• **LED Easy to use**

Compared with the traditional mercury bulb, the LED eliminate frequent bulb replacements, saving time and money. Also the problems of preheating, cooling and high temperature is solved.

## Suitable for a variety of fluorescent dyes

Equipped with 3 fluorescent filter blocks, it provides a wide range of choice of dyes and capture clear high contrast fluorescence images.

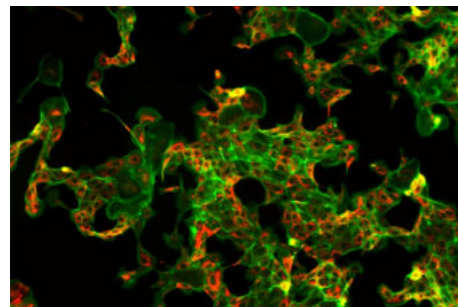

Breast cancer

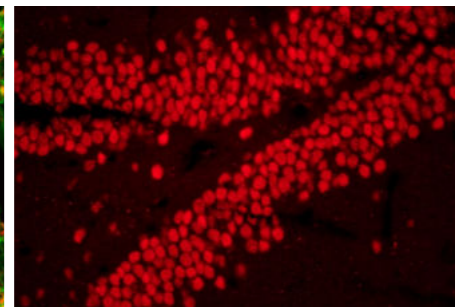

Hippocampus

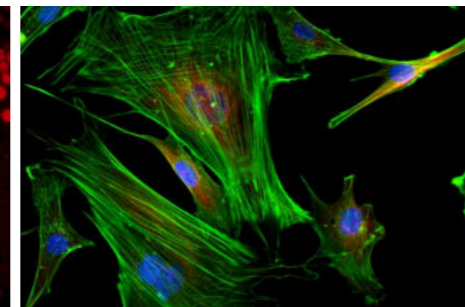

HC3T3 mouse brain nerve cells

## Contrast Shield

The Contrast Shield can effectively block the interference of the external light, increase the contrast of the fluorescent image, and provide a high signal-to-noise ratio fluorescent image. When need phase contrast observation, the Contrast Shield is very convenient to be removed from the light path, avoiding influence on the quality of phase contrast.

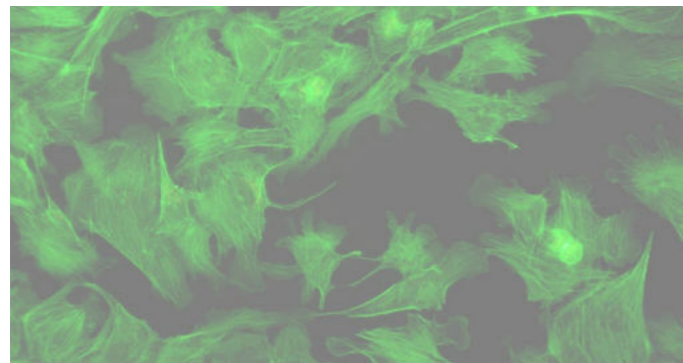

Without contrast shield

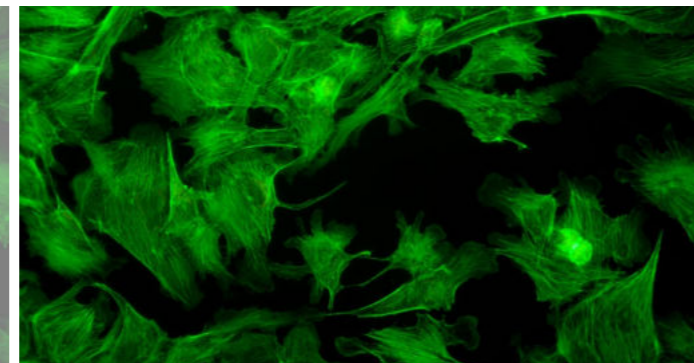

With contrast shield

## SYSTEM LAYOUT

For Nexcope NIB600 Microscope

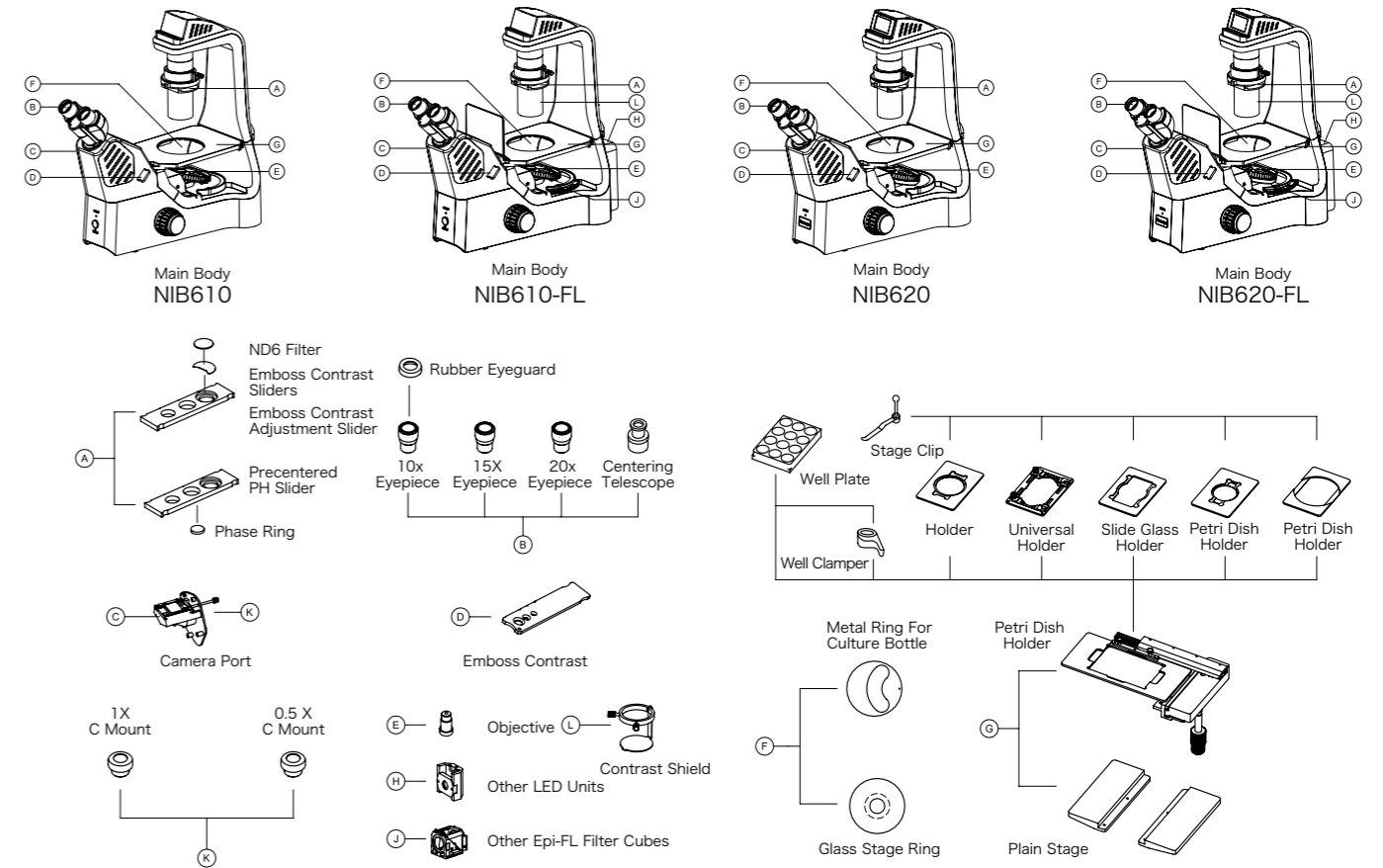

## DIMENSION FIGURE

(Unit: mm)

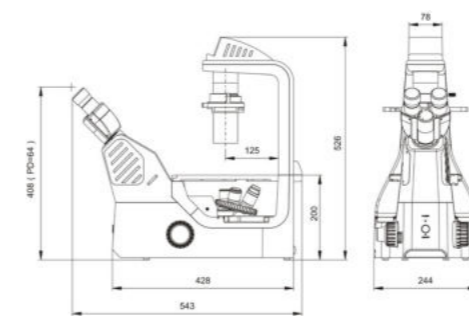

NIB610

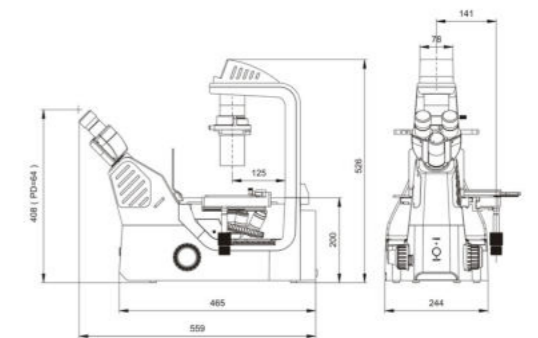

NIB610-FL

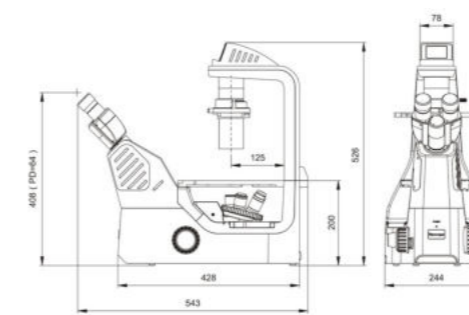

NIB620

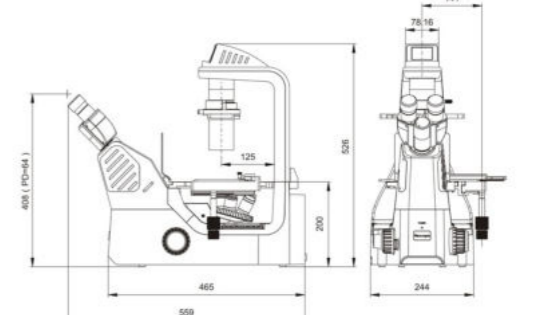

NIB620-FL